

BASE SECTION DETAIL
NOT TO SCALE

NOTES:

1. MANUFACTURED TO MEET OR EXCEED THE LATEST REVISIONS OF ASTM C478 AND AASHTO M199.
2. BUTYL MASTIC JOINT SEALTANT IN ACCORDANCE WITH AASHTO M198 AND ASTM C990.
3. ALL SECTIONS FURNISHED WITH OSHA RATED CAST-IN LIFTING INSERTS FOR HANDLING.
4. HOLES SIZED TO ACCOMODATE FLEXIBLE RUBBER CONNECTORS IN ACCORDANCE WITH ASTM C923.
5. CONCRETE:
 - A. STRENGTH:.....4,000 PSI, MIN. 28 DAYS
 - B. CEMENT:.....PORTLAND CEMENT PER ASTM C150
 - C. AGGREGATE:.....NATURAL PER ASTM C33
 - D. ADDITIVES:.....FLY ASH PER ASTM C618
6. STEEL REINFORCEMENT:
 - A. CONES, RISERS, AND BASE WALLS:.....0.18 SQUARE INCHES PER VERTICAL FOOT
 - B. BASE FLOORS:.....0.20 SQUARE INCHES PER LINEAL FOOT EACH WAY
7. PLASTIC ENCAPSULATED STEEL STEPS AT 16" OC TYPICAL.
8. TWO CAST-IN LIFT INSERTS AT APPROXIMATE BALANCE POINTS. APPROX 10" FROM TOP WITH #3 REBAR LOOP
9. FLAT SLAB TOP, CONES, BASES AND RISER DESIGNED FOR HS-20 LOADING
10. STEEL SHALL BE ASTM A-706 GRADE 60
11. CONE & RISER SECTION ABOVE TRANSITION SECTION PER STD. FOR 4' & 5' CONES & RISERS.
12. BURY OF MANHOLE SHALL BE LIMITED TO 40' MAX. USER OF MANHOLE SHALL BE RESPONSIBLE FOR PROVIDING A SUITABLE FOUNDATION

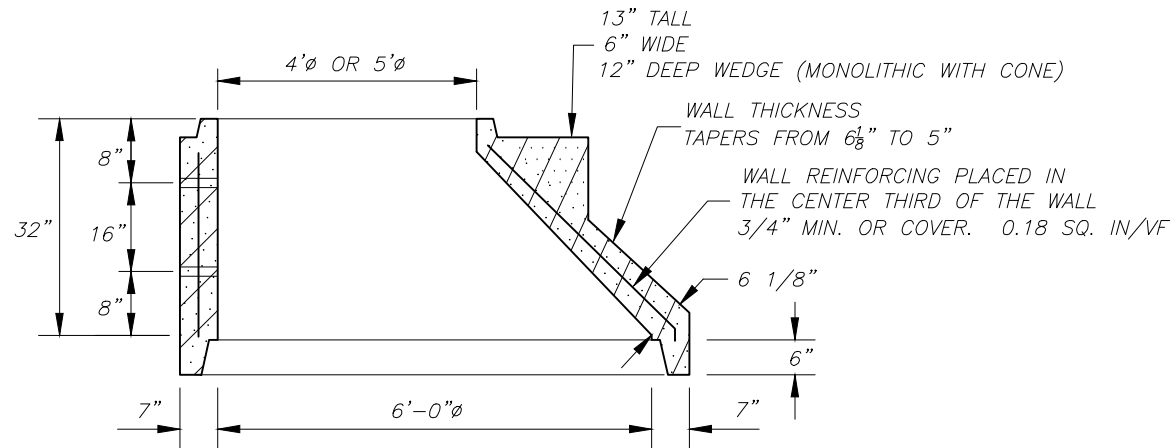

TRANSITIONAL CONE - 6' dia TO 5' dia or 4' dia
NOT TO SCALE

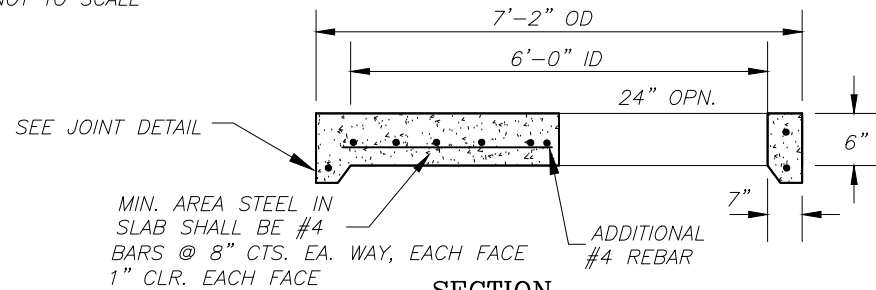

SECTION

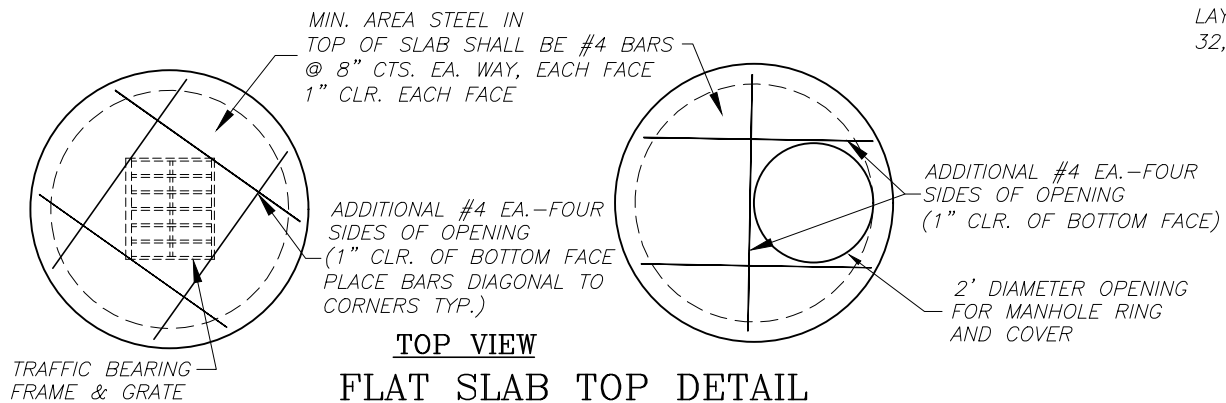

TOP VIEW
FLAT SLAB TOP DETAIL
NOT TO SCALE

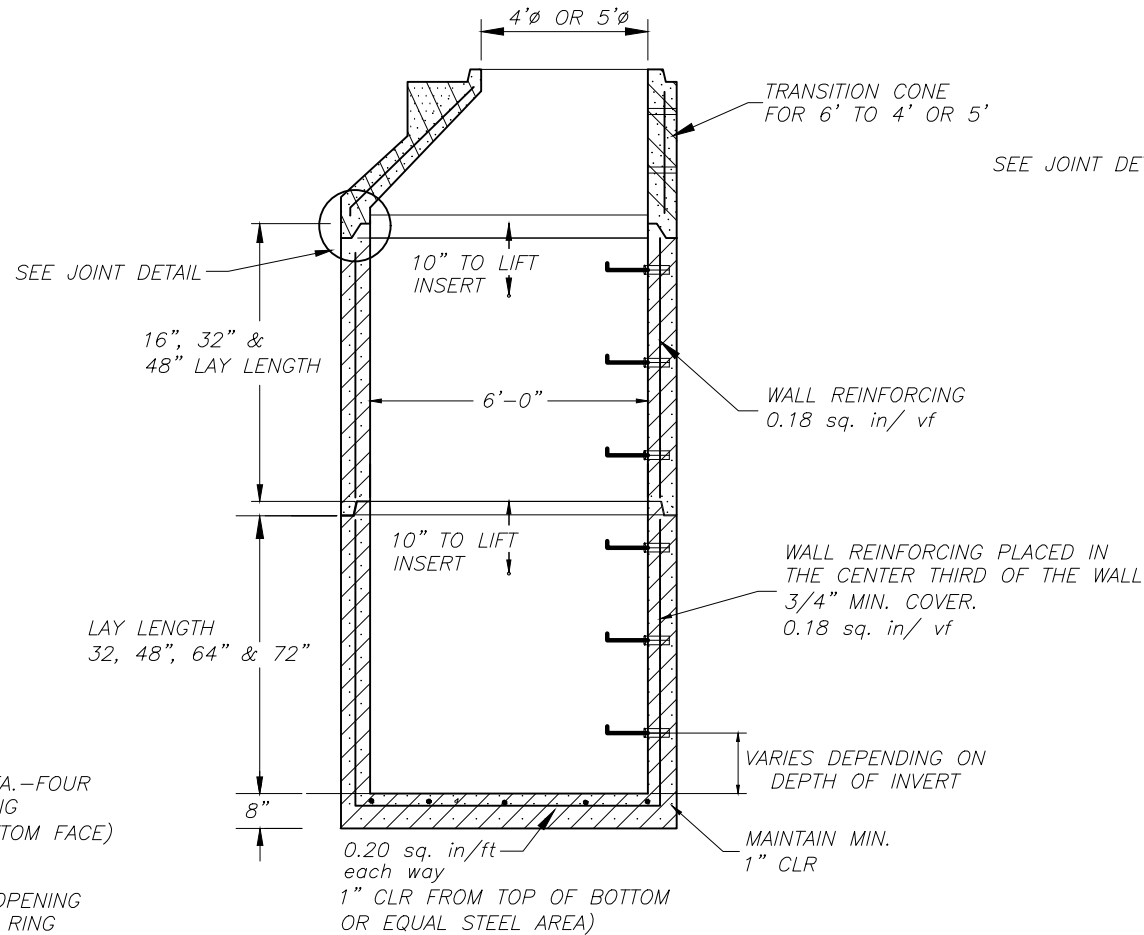

MANHOLE SECTION DETAIL
NOT TO SCALE

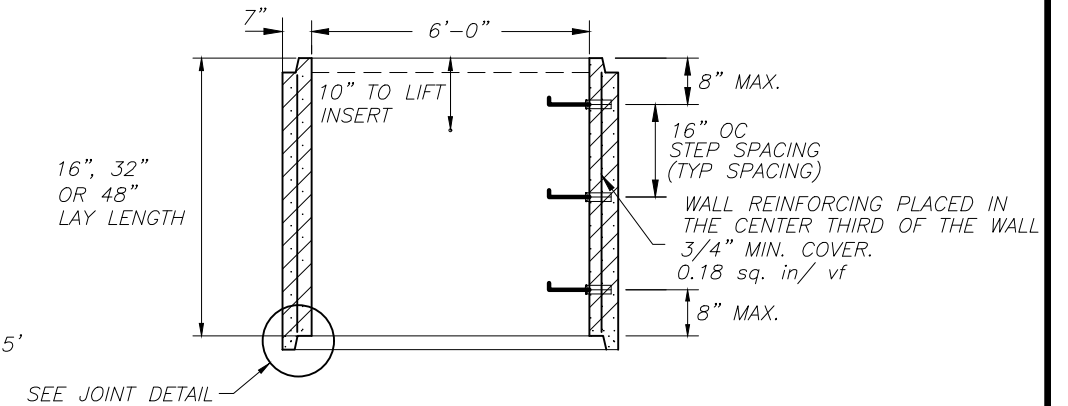

RISER SECTION DETAIL
NOT TO SCALE

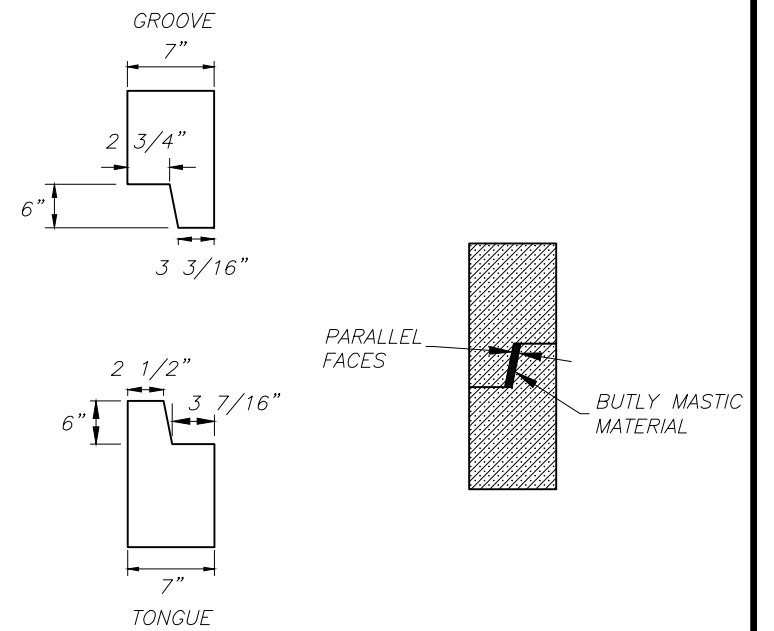

JOINT DETAIL
NOT TO SCALE

NO.	REVISIONS	DATE	BY

DESIGNED	MAW
DRAWN	LGC
CHECKED	MAW
PROJECT MANAGER	RHW

NOT TO SCALE



WRIGHT & ASSOCIATES
ENGINEERS & SURVEYORS
209 1ST AVE., SOUTH CONOVER, NC 28613
(828) 465-2205 OFFICE
(828) 465-5878 FAX
NC FIRM LIC. NO. C2242



6' DIA. MANHOLE
H-20 LOADING MANHOLE DETAILS

DATE: AUGUST, 2012
JOB NO.: 702-014
DRAWING NO.:
SHEET 1 OF 1